

Figure 1

Table of Contents

- 1. General... 1
- 2. Installation Steps..... 1
- 3. Step 1-Changing Cable stub
Position... 2
- 4. Step 2-Mounting..... 3
- 5. Step 3-Grounding... 4
- 6. Step 4-Splicing Cable Stub..... 6
- 7. Step 5-Marking and Jumpering..... 6
- 8. Step 6-Inserting Protector
Modules.....7
- 9. Step 7-Testing...8

1. General

1.1 This document is a basic guide for installing the High Density Connector. It applies only to C(G)-391 Connectors that are mounted on the left hand side of the frame vertical mounting bar and have a cable stub.

- 1.2 The C(G)-391 Central Office Connector has been designed to meet or exceed Bellcore Specification TR-EOP-000164.
- 1.3 This document is being reissued to include updated corporate information.

2. Installation Steps

Installation consists of seven sequential steps:

- 1 Changing Cable Stub Position.
- 2 Mounting
- 3 Grounding
- 4 Splicing Cable Stub.
- 5 Marking and Jumpering.
- 6 Inserting Protector Modules.
- 7 Testing

3. Step 1- Changing Cable Stub Position

The C(G)-391 Connector may be ordered in stub-up or stub-down position. If necessary, stub direction can easily be changed at the installation site.

3.1 Loosen two screws on stub mounting bracket (Figure 2).

3.2 Rotate stub to desired position.

3.3 Make sure stub mounting screw is in lock recess on stub mounting bracket. Firmly tighten both screws on stub mounting bracket to secure position.

⚠ CAUTION: Do not bend cable stub into a tight curve. Securely tighten stub mounting screws to ensure cable shield ground connection.

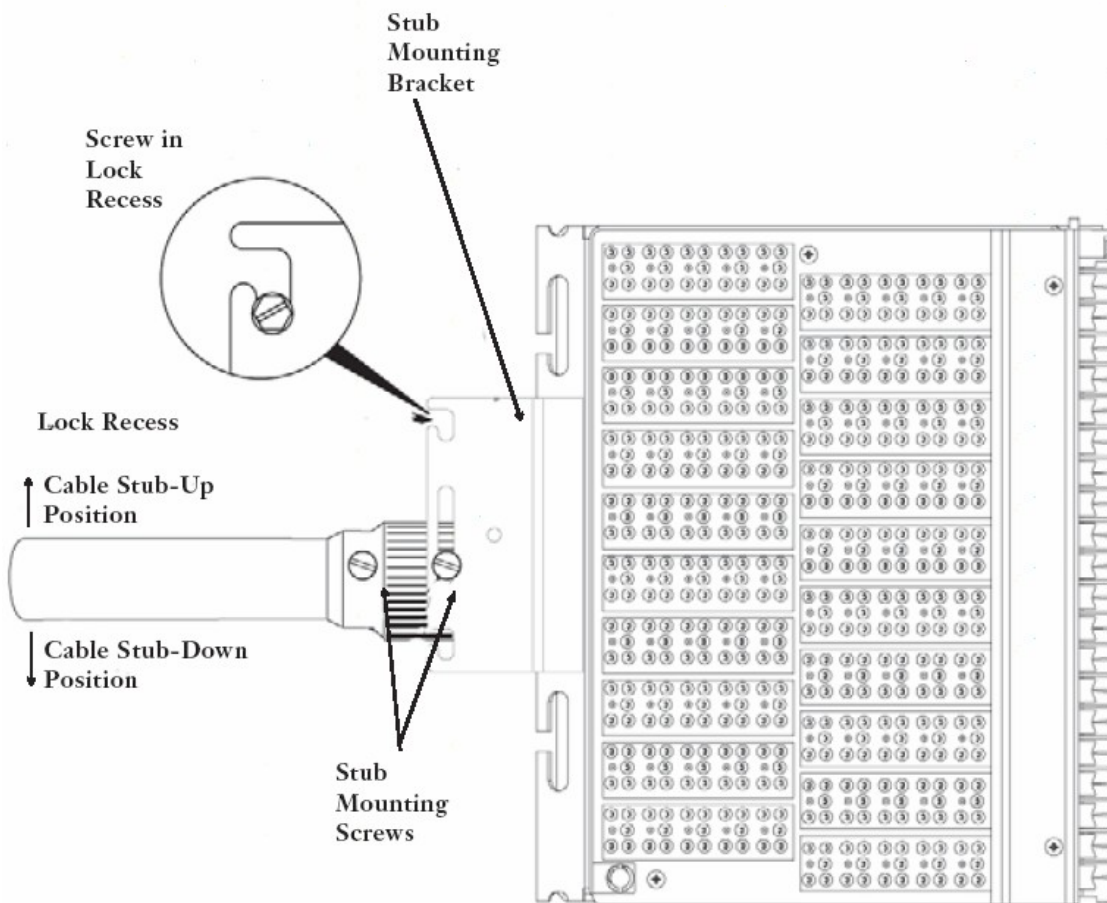

Figure 2

4. Step 2- Mounting

The C(G)-391 Connector mounting bracket has two slotted mounting holes and a half-hole at each end. Insert 1/4-24 screws (provided) through one mounting hole and one half-hole, or through two slotted mounting holes, and secure the C(G)-391 mounting bracket to the left hand side of frame vertical mounting bar (Figure 3).

NOTE: *Mounting hole patterns may differ at the top and bottom of some tall, conventional main distributing frames' vertical mounting bars. A special mounting bracket may be used to facilitate mounting the C(G)-391 Connector in these applications (Figure 3 inset).*

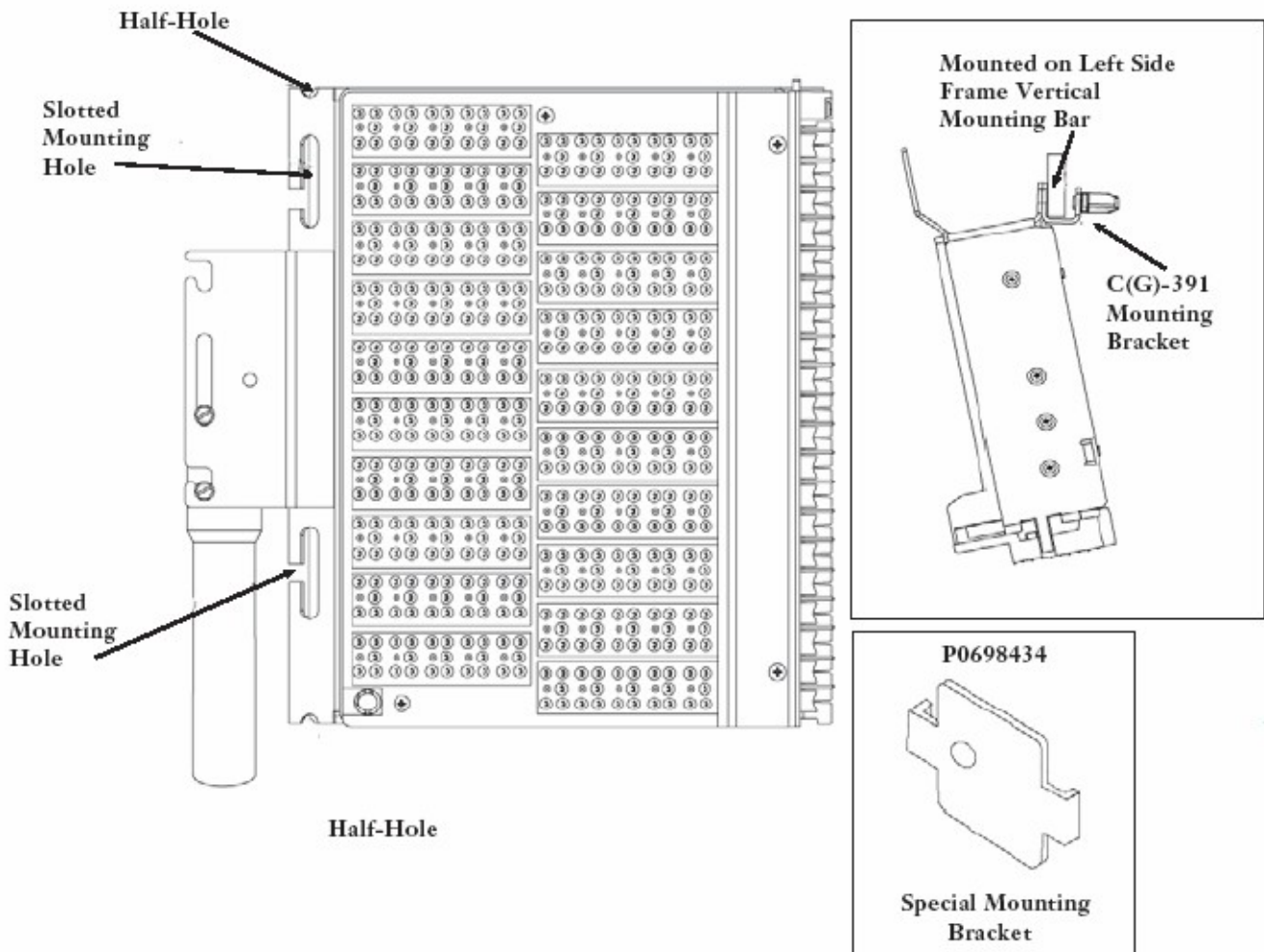

Figure 3

5. Step 3- Grounding

The C(G)-391 Connectors are configured for either frame grounding (NT8G1xxx- and NT8G2xxx- series), or independent grounding (NT8G6xxx- and NT8G8xxx- series). Connectors configured for independent grounding may be reconfigured for isolated grounding. Connectors configured for frame grounding cannot be reconfigured.

5.1 FRAME GROUND METHOD: Mount the C(G)-391 Connector to the main distributing frame by inserting the two mounting screws through the slotted mounting bracket. Ground straps or cables are not required.

5.2 When configured for independent grounding, the C(G)-391 Connector may easily be changed to isolated grounding (Figure 4).

5.2.1 Independent Grounding

- a. No. 6 AWG 11-inch group strap interconnects ground bars or vertically adjacent connectors. Last connector is connected to frame ground bar with a No. 6 AWG ground strap (not included).
- b. No 12 AWG ground strap connects cable shield ground to connector ground bar (Installed at factory). Refer to Figure 4 inset "A".
- c. Ground bracket connects connector ground bar (installed at factory). See inset "A".

5.2.2 Isolated Grounding.

- a. Follow steps 5.2.1 a and b as detailed in independent ground method.
- b. Remove independent ground bracket by loosening screw and removing screw 2 (Figure 4, inset "B") between connector ground bar and connector mounting bracket. Retighten screw 1 after removing ground bracket.

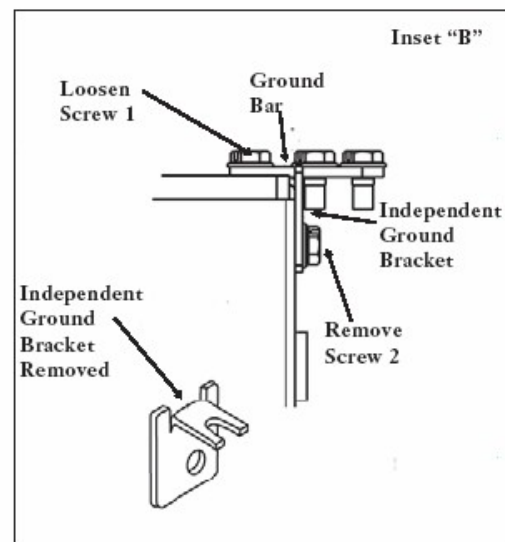
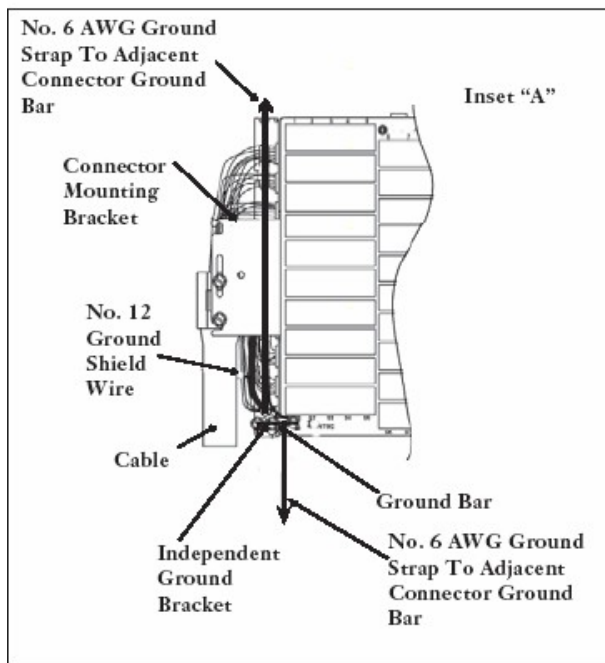
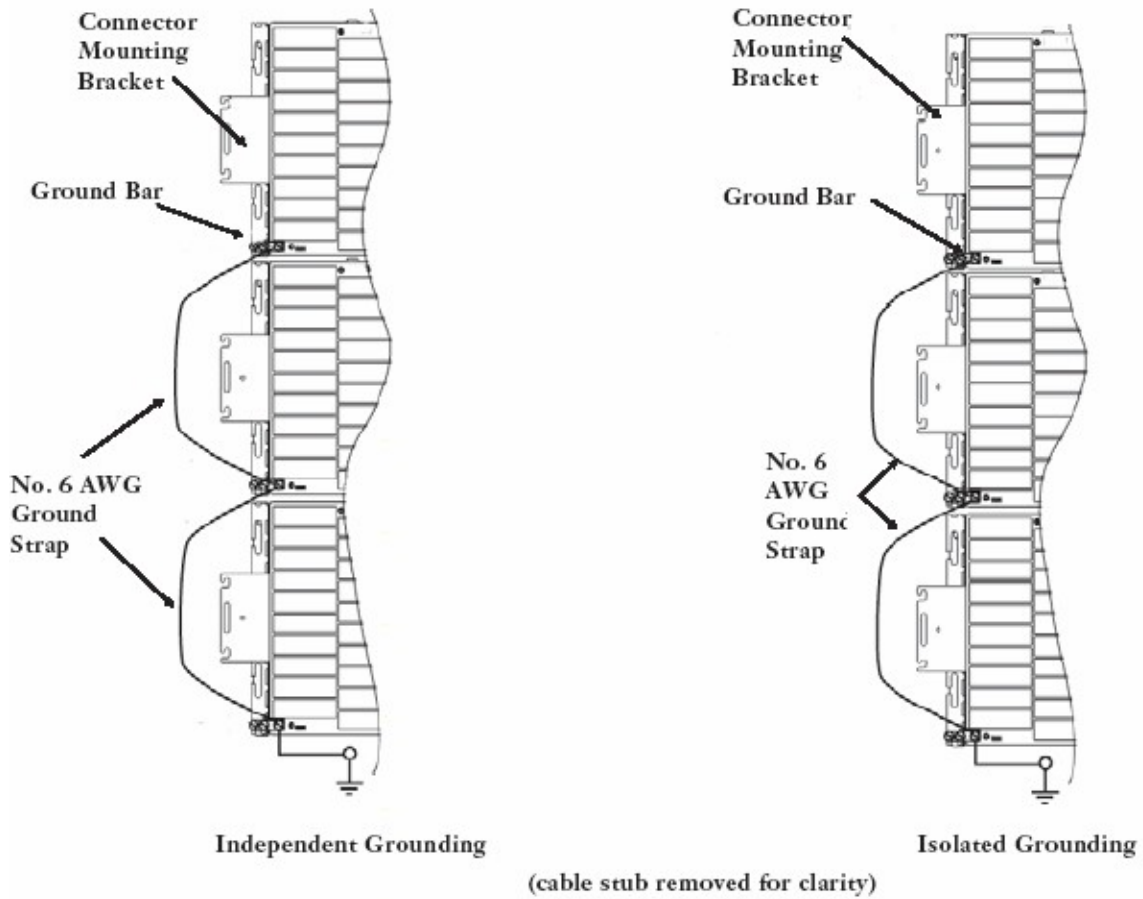

Figure 4

6. Step 4- Splicing Cable Stub

Cable stub wiring uses standard cable wire color codes. Match stub pairs to entrance cable pairs and follow local practices for splicing.

7. Step 5- Marking and Jumpering

Jumper terminals consist of 20 rows of quick-clip terminal. Each row of 5 terminals is identified by a number for easy pair identification (Figure 5).

7.1 Use appropriate stenciling kit to mark cable and pair numbers. Mark cable ID near "CA" area at top of connector; mark pair count ID near "PR" area at bottom of connector.

7.2 Insert five pairs of jumper wires into secondary fanning strip slot (pairs one through five in top slot).

7.3 Feed jumper wires into primary fanning strip. Bring first jumper wire pair forward, and wire-wrap jumper wires to terminal pins.

7.4 Dress each wire along bottom of appropriate row of terminal pins.

7.5 Repeat the steps above for the remaining jumper pairs.

7.6 Dress wire slack to rear of C(G)-391 Connector. Jumper pairs should run neatly from terminal field across connector backplane.

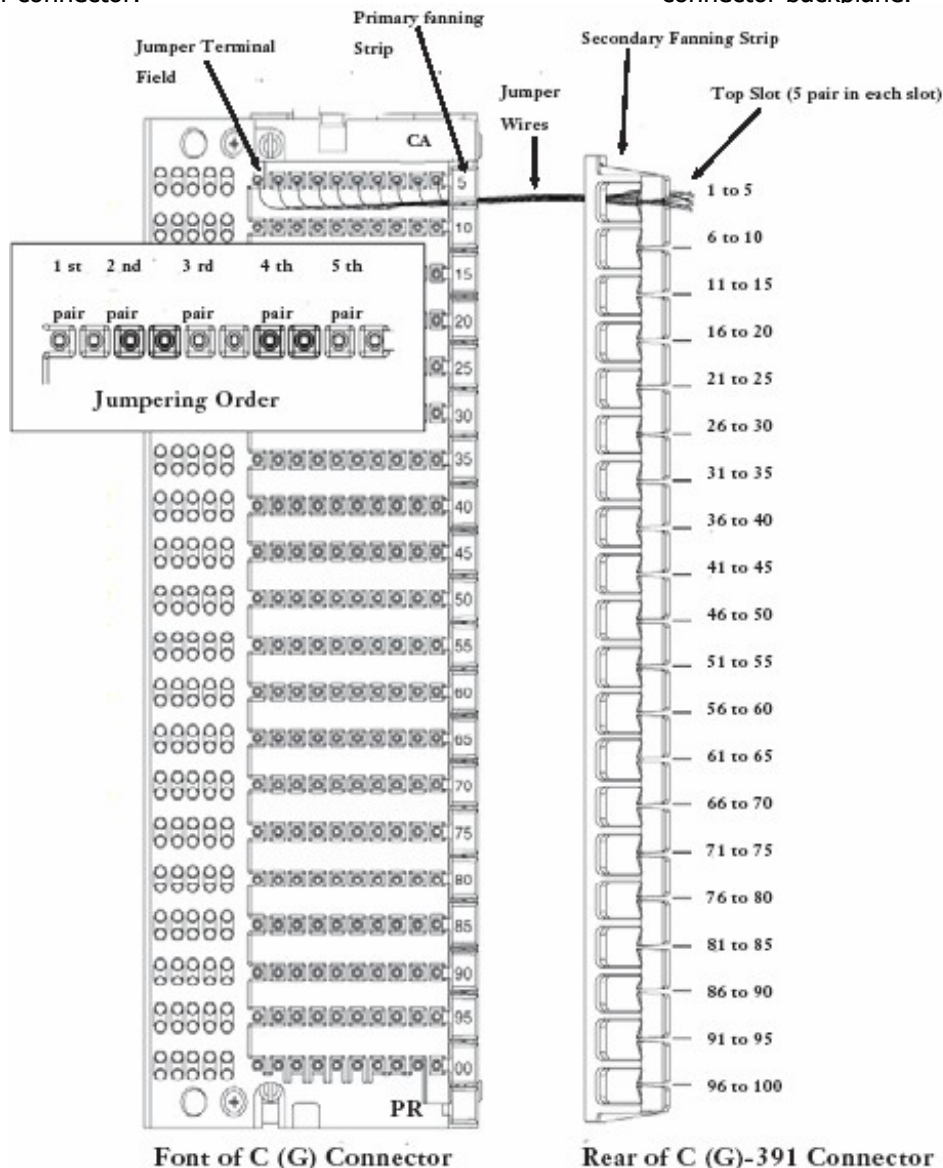

Figure 5

8. Step 6—Inserting Protector Modules

The protector field is located on the left side of the C(G)-391 Connector. Numbers at the top and right side of the protector field identify wire pairs. The protector field is keyed so that protector modules can only be installed one way (Figure 6).

NOTE: Use appropriate test set to check protector modules for tip and ring continuity and ground.

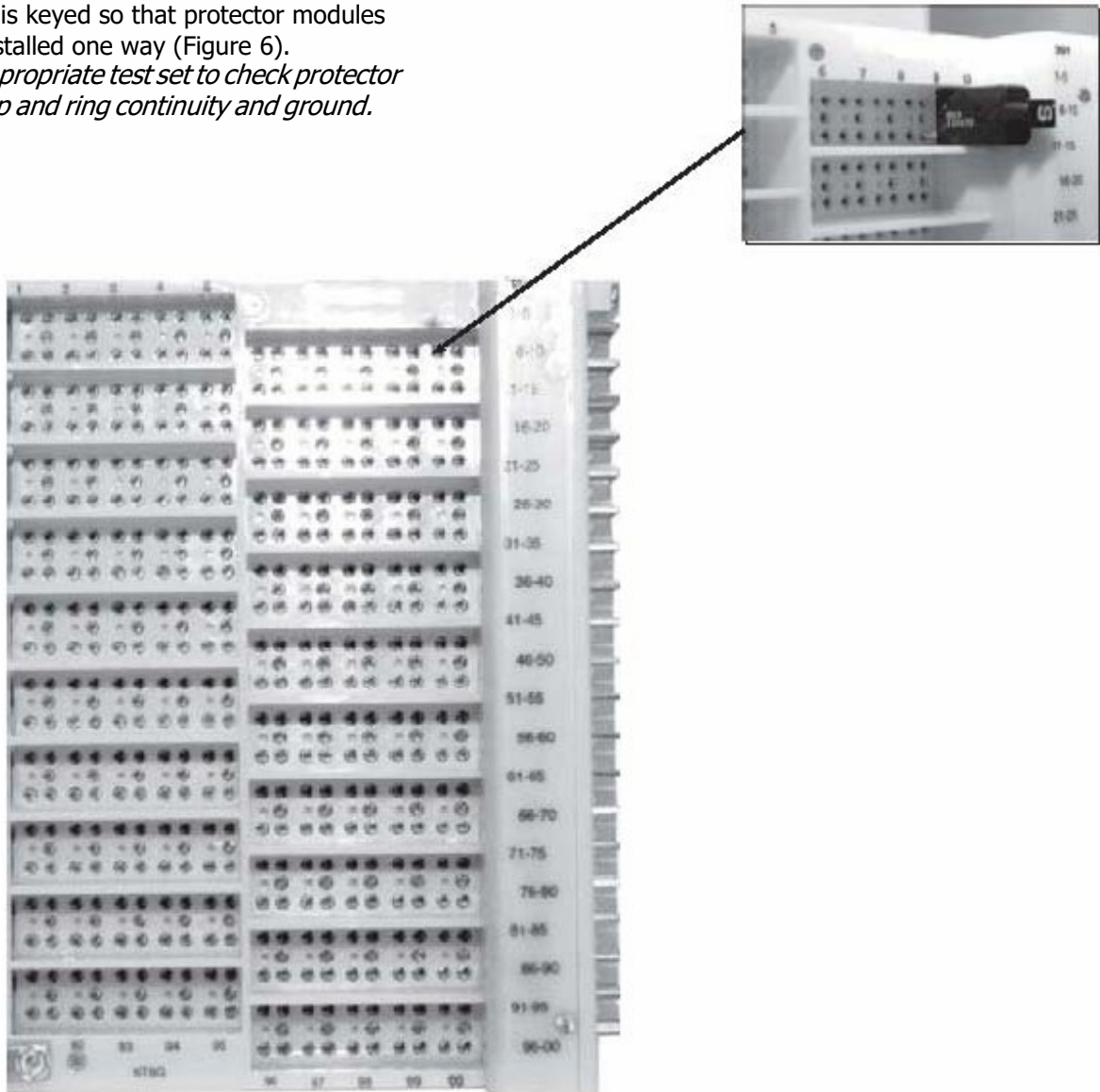
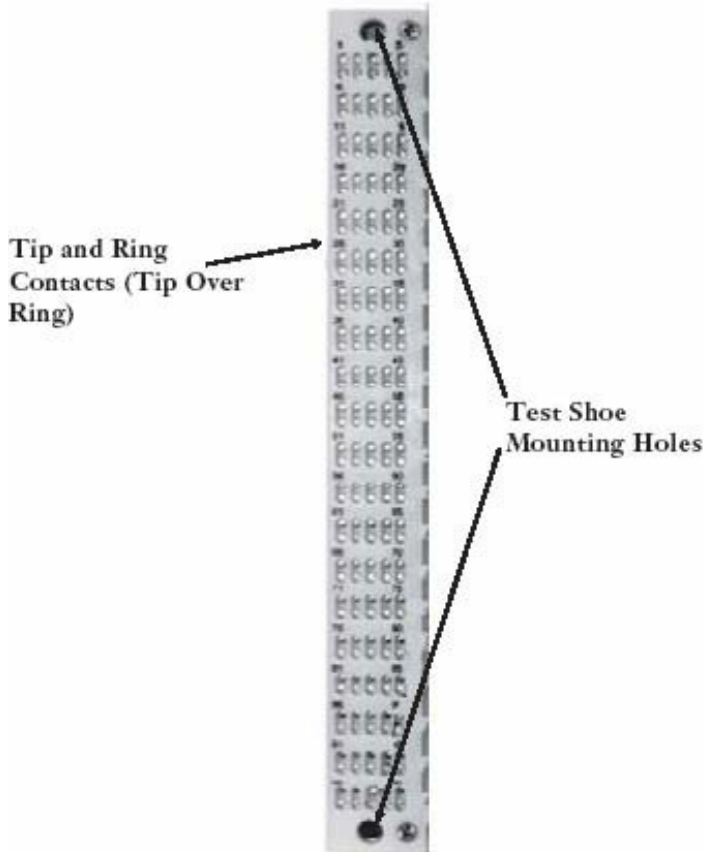

Figure 6

8.1 Insert protector modules to “detent” position during installation (Figure 6 inset). Detent position protects OSP pairs, but keeps OSP pairs disconnected from Central Office (CO) equipment.

8.2 After installation steps have been completed, push each protector module into its fully inserted position. This connects CO pairs to OSP pairs.

9. Step 7—Testing



9.1 The C(G)-391 test field consists of 100 pairs of gold-plated contacts. Test points are connected directly to OSP cable with separate connections for tip and ring of each pair. Test field terminals are numbered to show beginning and end of each row of five terminals (Figure 7).

- 1,5
- 6,10
- 11,15 (through...)
- 96,00 (100)

Use NT8G99AA Single-pair test cord or A0354444 100-pair test connector to test connections.

NOTE: *The C(G)-391 is also designed to be used with AT&T model P2FM single-pair test cord, and AT-8987 T-test connector.*

Figure 7